

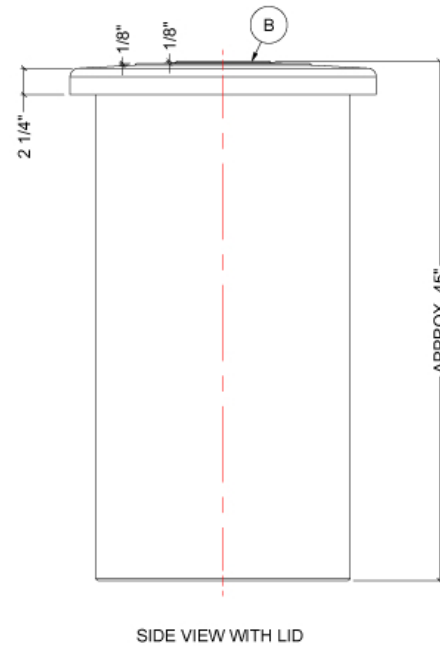

- NOTES:
1. TANK IS MANUFACTURED TO ASTM-D-1998 STANDARD.
 2. ALL DIMENSIONS ARE APPROXIMATE.

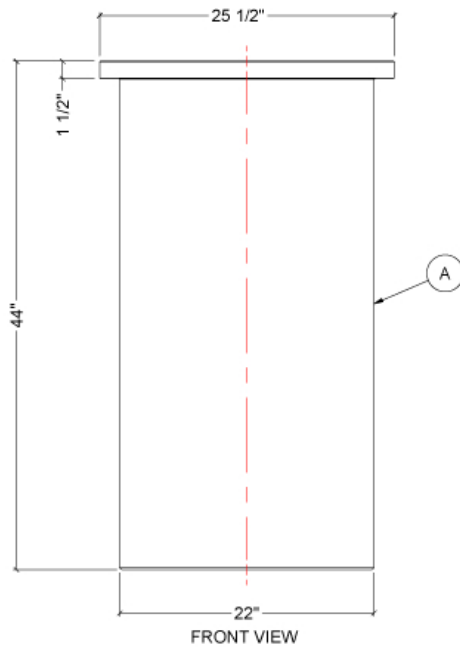

MATERIALS LIST		
ITEMS	DESCRIPTION	NOTES
A	OT-60 OPEN TOP TANK	
B	LID FOR OT-60	

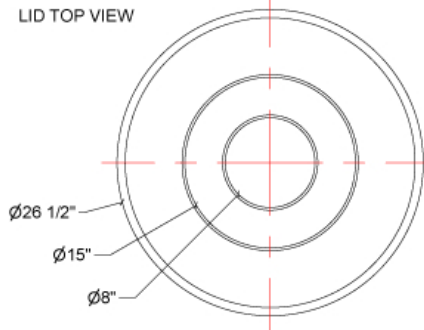
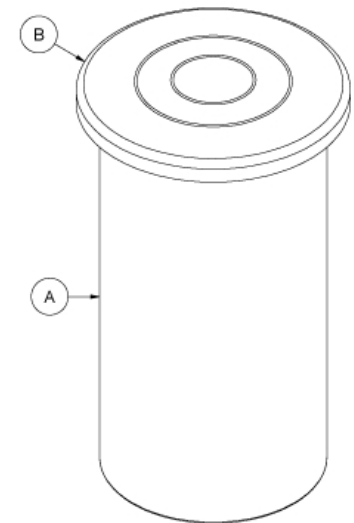

REV	DATE	DESCRIPTION	BY	APPO	REVD
REVISIONS					
CUSTOMER					
TITLE		ACO JOB NO:			
60 IG OPEN TOP TANK		PURCHASE ORDER NO:			
		PURCHASER'S EQUIP. NO:			
THIS DRAWING IS THE PROPERTY OF ROTOPLAST INC. AND SHALL NOT BE COPIED OR TRANSFERRED WITHOUT THE WRITTEN CONSENT OF ROTOPLAST INC.					
ENGINEERS SEAL		 MAS PRECISION PLASTICS Real Service. Real Solutions.			
		DESIGNED			
		DRAWN			WM
		CHECKED			
		APPROVED			
		SCALE			N.Y.S.
		DATE			03-03-16
DWG NO		OT-60-L			REV
					0